

MasterFlow 765

Non Shrink Construction Grout

DESCRIPTION

MasterFlow 765 is a ready to use, non-shrink construction grout. It can be used from fluid to plastic consistencies for grouting of equipment and machinery, bearing pads, rails and anchoring.

FIELD OF APPLICATION

MasterFlow 765 is recommended for:

- Grouting bearing pads and plinths
- Grouting under machinery base plates, stanchion bases and crane rails
- Anchoring bolts, reinforcing bars and rods
- Underpinning

FEATURES AND BENEFITS

- Non shrink for effective contact and support
- High early strength for rapid installation and use of plant
- Durable, uniform dense structure
- Good workability for up to 1 hour at 20°C

Can be applied in thicknesses ranging from 10-100mm

APPLICATION METHOD

(a) Surface Preparation

The concrete should be free of frost, curing membranes, waterproofing treatments, oil stains, laitance, friable material and dust.

The concrete surfaces should be chipped and if there is a water leakage it must be drained or properly plugged. Soak area to be grouted with water for 24 hours prior to grouting to minimise localised absorption and to assist in the free flow of the grout. Surfaces should be damp but free of standing water. Particular attention should be paid to bolt holes to ensure that these are water-free. Use oil free compressed air to blow out bolt holes and pockets as necessary.

Base plates, bolts, etc. must be clean and free of oil, grease and paint etc. Set and align equipment. If shims are to be removed after the grout has set, then lightly grease them for easy removal.

(b) Formwork

Ensure formwork is secure and watertight to prevent movement and leaking during the placing and curing of the grout. The area should be free of excessive vibration. Shut down adjacent machinery until the grout has hardened.

Formwork should be designed to allow a hydrostatic head of 150mm to be maintained throughout.

On the side where the grout is to be poured, allow 150mm clearance between the sides of the form and the base plate of the machine.

On the opposite side allow at least 50-100mm for the head of the grout and 50mm clearance between the formwork and the edge of the base plate.

(c) Mixing

For optimum results a high shear paddle or vane grout mixer should be used. Colloidal impeller mixers are not suitable for use with this product. Air entrainment should be avoided.

For large or continuous placement ensure that adequate mixing capacity and sufficient labour is available. A holding tank fitted with agitation may be required.

Add the correct amount of water for the required consistency to the mixer and then add the complete pack(s) slowly while mixing. Mix for 3-5 minutes depending upon mixer, until a smooth, uniform, lump free consistency is achieved.

The following indicates the appropriate quantity of water required to mix a 25kg bag of MasterFlow 765 grout to various consistencies at the temperature shown.

Water demand (litres per 25kg bag)			
Consistency	Fluid	Flowable	Plastic
Temperature 20°C	4.5	4.0	3.0

A trial mix may be required to establish the correct water content, which will depend upon mixing equipment and site temperatures.

(d) Application Underplate

Ensure sufficient material is available to complete the work and obtain a continuous fill.

Fill all the bolt pockets with grout before pouring the rest of the underplate grout. Pour the grout continuously from one side only to avoid air entrapment. Maintain a constant hydrostatic head of approximately 150mm, to promote flow. DO NOT vibrate. Lengths of metal or plastic strapping laid in the formwork prior to placing can be used to aid complete filling.

MasterFlow 765

Non Shrink Construction Grout

GROUTING LARGE VOLUMES:

Where the thickness of grout exceeds 100 mm the addition of clean, graded 10mm aggregates at up to one to one by weight is recommended. In this instance normal concrete mixers and pumps may be used.

PUMPING

MasterFlow 765 may be placed using piston, ram or diaphragm type grout pumps fitted with ball valves.

PLACING TECHNIQUES

Diagram (A) illustrates typical placement of MasterFlow 765 in the flowable state utilising straight pouring or pumping techniques to place a bedding mortar under bearing plates. Note that unrestrained areas around baseplates should always be kept to a minimum.

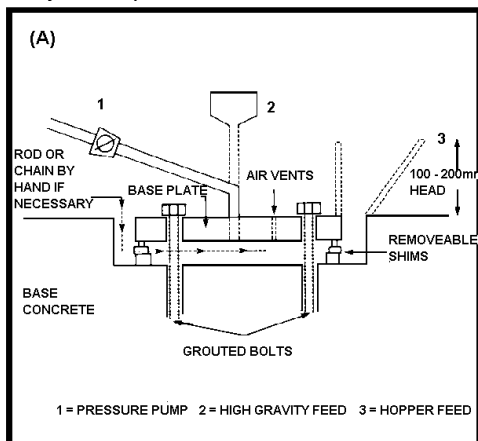

UNRESTRAINED AREAS

Even with good curing, unrestrained areas of grout, for example around baseplates, may exhibit drying shrinkage cracking some time after placement. This is not detrimental to the performance of the grout where it is restrained under the plate or bearing, but may affect the cosmetic appearance of the application.

COVERAGE

25kg of MasterFlow 765 mixed with 4.5 litres of water produces 13.4 litres of grout.

75 x 25kg bags of grout per m³. Using more or less water to meet consistency requirements will increase or decrease the yield accordingly. When estimating due allowance for wastage must be made.

FINISHING AND CLEANING

Tools and mixer must be cleaned immediately after use with water. Cured material can only be removed mechanically.

CURING

Good curing is essential on all exposed surfaces particularly in dry, sunny conditions. Failure to do so will reduce bond, strength and durability. Immediately after finishing apply 1 coat of MasterKure 181SB to all exposed surfaces. Alternative methods are water ponding, mist spraying and the like, but in all cases these must be maintained for at least 7 days. Keep the grout above 5°C at all times during application and cure.

WORKING TIME

45 minutes in 20 °C ambient and substrate temperature.

PACKAGING

MasterFlow 765 is packed in 25kg bags.

STORAGE

Store at ambient temperatures, out of direct sunlight, in cool, dry warehouse conditions and clear of the ground on pallets protected from rainfall prior to application.

SHELF LIFE

Up to 1 year when stored in unopened containers depending upon storage conditions. Refer also to best before date.

WATCH POINTS

- Do not apply at temperatures below +2 °C nor above +35 °C.
- Do not add any other substance that could affect the properties of the product. In case of thicker applications and complex geometries consult your local Master Builders Solutions representative.
- Do not use water in an amount or at a temperature that will produce a consistency more than fluid or cause mixed grout to bleed or segregate.
- Under no circumstances should MasterFlow 765 be re-tempered by the later addition of water.

MasterFlow 765

Non Shrink Construction Grout

HANDLING AND TRANSPORT

Usual preventive measures for the handling of chemical products should be observed when using this product, for example do not eat, smoke or drink while working and wash hands when taking a break or when the job is completed.

Specific safety information referring the handling and transport of this product can be found in the Material Safety Data Sheet. For full information on Health and Safety matters regarding this product the relevant Health and Safety Data Sheet should be consulted.

Disposal of product and its container should be carried out according to the local legislation in force. Responsibility for this lies with the final owner of the product.

CONTACT DETAILS

BASF plc,
Construction Chemicals,
19 Broad Ground Road
Lakeside
Redditch
Worcestershire
B98 8YP
Tel: +44 (0) 1527 512255
Fax +44 (0) 1527 503576
www.master-builders-solutions.basf.co.uk

© BASF plc, Construction Chemicals

MasterFlow 765

Non Shrink Construction Grout

Product Data				
Property		Standard	Data	Unit
Chemical Base		-	Cement	-
Color		-	Grey	-
Layer Thickness	minimum maximum	-	10 100	mm
Fresh Mortar Density		-	Approx. 2,200	kg/m ³
Workability (Flow Cone Efflux time) at 4.5 litres water/bag		Astm standard C939-87	13 (for 1 litre) 30 (to empty)	Seconds
Mixing Water range for 25 kg Bag		Fluid Flowable Plastic-	4.5 4.0 3.5	litres
Gaseous Expansion		Astm C 827	≥ 0.5	%
Application Temperature (ambient and substrate)		-	+5 - +35	Celcius
Compressive Strength ¹ (20 °C)	1 day 3 days 7 days 28 days 3 months 6 months 12 months	EN 196-1	≥20 ≥40 ≥55 ≥70 ≥75 ≥75 ≥80	N/mm ²

Note: ¹ Hardening times are measured at 21°C ± 2°C and 60% ± 10% relative humidity. Higher temperatures will reduce these times and lower temperatures will extend them. Technical data shown are statistical results and do not correspond to guaranteed minima. Tolerances are those described in appropriate performance standards.

MasterFlow 765

Non Shrink Construction Grout

MasterFlow 765 - BASF plc, Construction Chemicals, Version 1

Health and Safety

*For full information on Health and Safety matters regarding this product the relevant Health and Safety Data Sheet should be consulted.

The following general comments apply to all products.

As with all chemical products, care should be taken during use and storage to avoid contact with eyes, mouth, skin and foodstuffs, (which may also be tainted with vapour until the product is fully cured and dried). Treat splashes to eyes and skin immediately. If accidentally ingested, seek medical attention. Keep away from children and animals. Reseal containers after use.

Solvent Based Products

Use in well ventilated areas; avoid inhaling. Suitable respiratory equipment may be needed, eg when spraying. Can cause skin, eye irritation. Wear protective eye shields and gloves during use. Do not smoke or allow sparks or naked lights when stored or in use.

Resin Products

Can cause irritation, dermatitis or allergic reaction. Use protective equipment particularly for skin and eyes. Use only in well ventilated areas.

Spillage

Chemical products can cause damage; clean spillage immediately.

DISCLAIMER

"BASF plc, Construction Chemicals" (the Company) endeavours to ensure that advice and information given in Product Data Sheets, Method Statements and Material Safety Data Sheets (all known as Product Literature) is accurate and correct. However, the Company has no control over the selection of its products for particular applications. It is important that any prospective customer, user or specifier, satisfies him/her-self that the product is suitable for the specific application. In this process, due regard should be taken of the nature and composition of the background/base and the ambient conditions both at the time of laying/applying/installing the material and when the completed work is to be brought into use.

Accordingly, no liability will be accepted by the Company for the selection, by others, of a product, which is inappropriate to a particular application.

Products are sold subject to the Company's standard conditions of sale and all customers, users and specifiers, should ensure that they examine the Company's latest Product Literature.