

WABO[®]DEC P

Pot bearings

Description

WABO[®]DEC P bearings consist of a steel baseplate housing a ring into which a rubber disc is fitted. The former ring is closed above a steel pressure plate engaging with a slight clearance into the circular baseplate recess. Rubber is retained in all directions and, behaving as an incompressible liquid, affords rotations on all axes.

To allow for sliding, the pressure disc is faced on top with a 4 mm thick partly recessed PTFE layer. The disc is also placed in contact with a steel plate lined with stainless steel high-mirror-finished-sheet. On guide bearings guide bars restricts the movement in one direction and resists horizontal forces perpendicular to the direction of translations. High-grade anticorrosion treatments and dustproofing gaskets adequately protect sliding surfaces.

Uses

WABO[®]DEC P steel/PTFE bearings, of the elastomer-based retained disc type are used as structural bearings for bridges since they are designed to support large vertical loads whilst on occasions resist horizontal loading and accommodate movement in a variety of directions. These bearings are supplied in three types: fixed, PF (Fig.1), guided, PG (Fig.2) and free-sliding, PM (Fig.3).

Benefits

- High resistance to horizontal stress
- High resistance to dynamic loads
- High durability
- Reduced maintenance

Packaging

WABO[®]DEC P bearings are supplied complete with identification plate bearing main data such as: date, type, bearing capacity and service displacement range.

transit plates to be removed after placement ensure product protection during shipment.

Product data

EN 10025 - S3 or higher grade steel is used.

Stainless steel is EN 10088 - X5 Cr Ni Mo 17/12. Surfaces in contact with PTFE are polished and feature roughness $Ra \leq 0.1$ mm, according to BS EN 1337.

PTFE is a virgin, polytetrafluorethylene produced by free deposition instead of thickening, 4 mm minimum thickness, featuring the following specifications:

*Properties

| | |
|----------------------------|------------------------------|
| Density | 2,170 ± 30 kg/m ³ |
| Tensile strength (23°C) | ≥ 24 N/mm ² |
| Elongation at break (23°C) | ≥ 300% |
| Hardness, Shore D | ≥ 55 |

WABO[®]DEC P

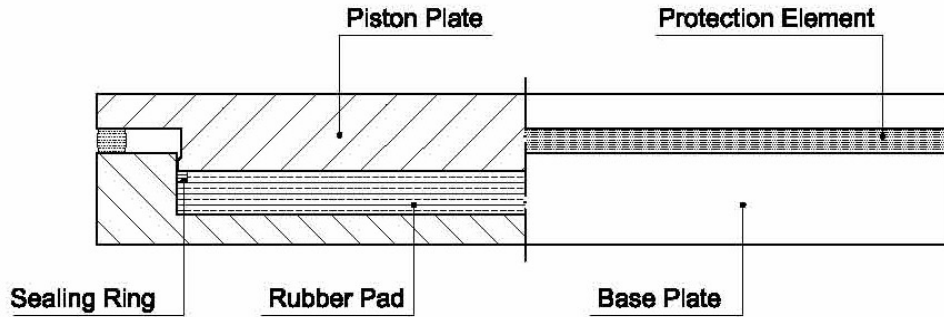

Figure 1: Cross-section of a Fixed Bearing (Wabodec PF)

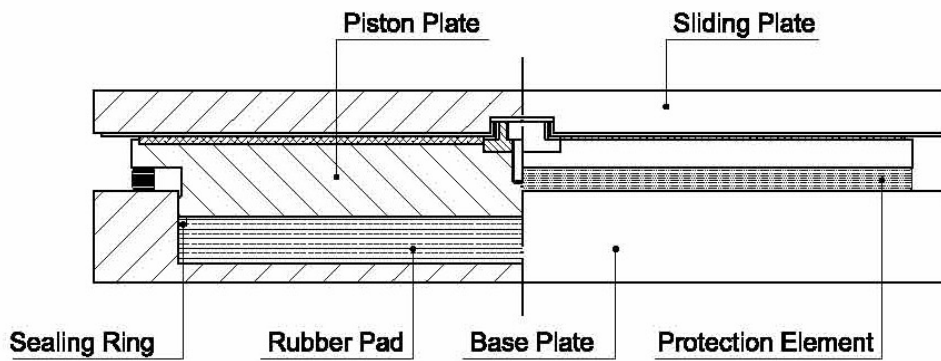

Figure 2: Cross-section of a Sliding Guided Bearing (Wabodec PG)

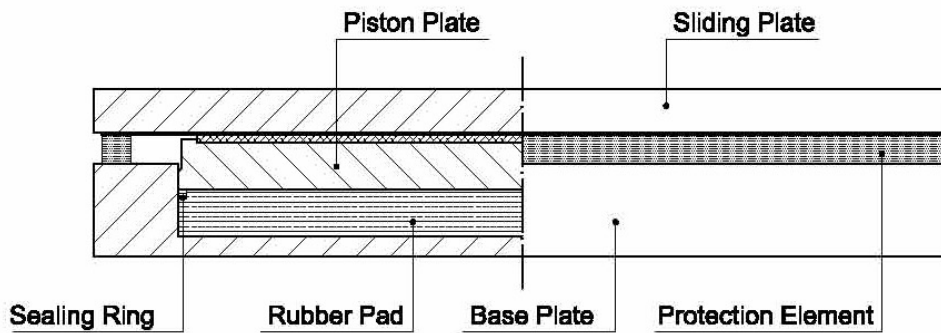

Figure 3: Cross-section of a Free Sliding Bearing (Wabodec PM)

WABO[®]DEC P

Non-aggressive grade silicon grease effective between -35°C to $+50^{\circ}\text{C}$ range according to DIN 51556 is used.

Anticorrosion treatment:

- Sandblasting to SA3 quality
- Epoxy primer 80 micron coat
- Two epoxy paint coats, 60 micron thick each

The elastomeric disc shall comply with UNI CNR 10018/87 standards and feature Shore A hardness equal to 50 ± 5 .

Upon request, bearings produced with different materials and/or anticorrosion protection can be supplied. Bearings complying with different standards such as AASHTO, DIN, BS 5400, BS EN 1337, SETRA, NBN, etc. can also be supplied. The anchoring system can be modified according to specific project installation requirements as well.

Tests and approvals

Installed on behalf of ANAS (Italian Trunk Road Board) and other Italian Road & Highway Management Boards. Approved by Italian Railways Authority (FS).

Storage

When bearings are not directly installed upon supply they shall be stored in an adequate place, raised from the ground, and in such way as to be protected from shock, dust, humidity and direct sun rays.

Installation

WABO[®]DEC P bearings must be correctly positioned for optimum operation and long service life. The area of contact between concrete and bearing surface shall be dimensioned to an average pressure below 150 kg/cm^2 , under maximum vertical load conditions; in case of higher values, provision must be made to reinforce the concrete.

Mode of fixing bearings to the structure depends on the given load conditions. It can be carried out by epoxy resin bonding, in which case with knurled-finish surfaces; or by means of anchors to be buried into concrete, making provision for steel counterplates – if any. Fixing to steel structures shall be solely made by means of screws.

This operation provides for the following main steps:

- Plynth to be cast up to an elevation some centimeter less than the elevation provided for housing the bearing systems; if anchors are to be used for fixing, bore the applicable holes in the required diameter, or allow full pockets prior to casting plynth;
- Positioning of bearings making use of adequate wedges;
- Fixing of bearings by epoxy resin injection.

Guided and free-sliding bearings must be pre-set in order to allow for any elongations and shortenings expected to take place in the structure. Presetting is performed prior to bearing locking by means of the special plates.

WABO[®]DEC P

Misalignment – if any – shall be eliminated fitting adequate levelling layers onto pre-cast beams, or placing a resin prism between bearing and superstructure, or alternatively making use of steel wedge in adequate size.

Your WBA Representative shall be pleased to provide additional detailed information.

Health and safety

Appropriate health and safety advice can be found in the Material Safety Data Sheets.

Users are advised to wear gloves and eye protection when installing WABO[®]DEC P bearings.

Note

Field service, where provided, does not constitute supervisory responsibility. For additional information contact your local BASF representative.

BASF reserves the right to have the true cause of any difficulty determined by accepted test methods.

Quality and care

All products originating from BASF's Dubai, UAE facility are manufactured under a management system independently certified to conform to the requirements of the quality, environmental and occupational health & safety standards ISO 9001, ISO 14001 and OHSAS 18001.

* Properties listed are based on laboratory controlled tests.

BASF_CC-UAE/Wabo_DecP_05_03/v2/10_14

STATEMENT OF RESPONSIBILITY

The technical information and application advice given in this BASF publication are based on the present state of our best scientific and practical knowledge. As the information herein is of a general nature, no assumption can be made as to a product's suitability for a particular use or application and no warranty as to its accuracy, reliability or completeness either expressed or implied is given other than those required by law. The user is responsible for checking the suitability of products for their intended use.

NOTE

Field service where provided does not constitute supervisory responsibility. Suggestions made by BASF either orally or in writing may be followed, modified or rejected by the owner, engineer or contractor since they, and not BASF, are responsible for carrying out procedures appropriate to a specific application.
